

Polymer PTC Resettable Fuse: KRH Series

125°C Radial Leaded Type



■ Features

1. RoHS & Halogen-Free (HF) compliant
2. Radial leaded devices
3. Resettable devices for automotive applications
4. Hold current ratings from 0.5A to 15A
5. Maximum voltage: 16Vdc & 32Vdc
6. Operating & storage temperature range: -40 ~ +125°C
7. AEC-Q200 compliant
8. Agency approval: UL / cUL / TUV



■ Recommended Applications

1. Protection of automotive electronics modules
2. I/O protection of ECU
3. EMI suppression
4. Prevention of ESD damage

■ Part Number Code

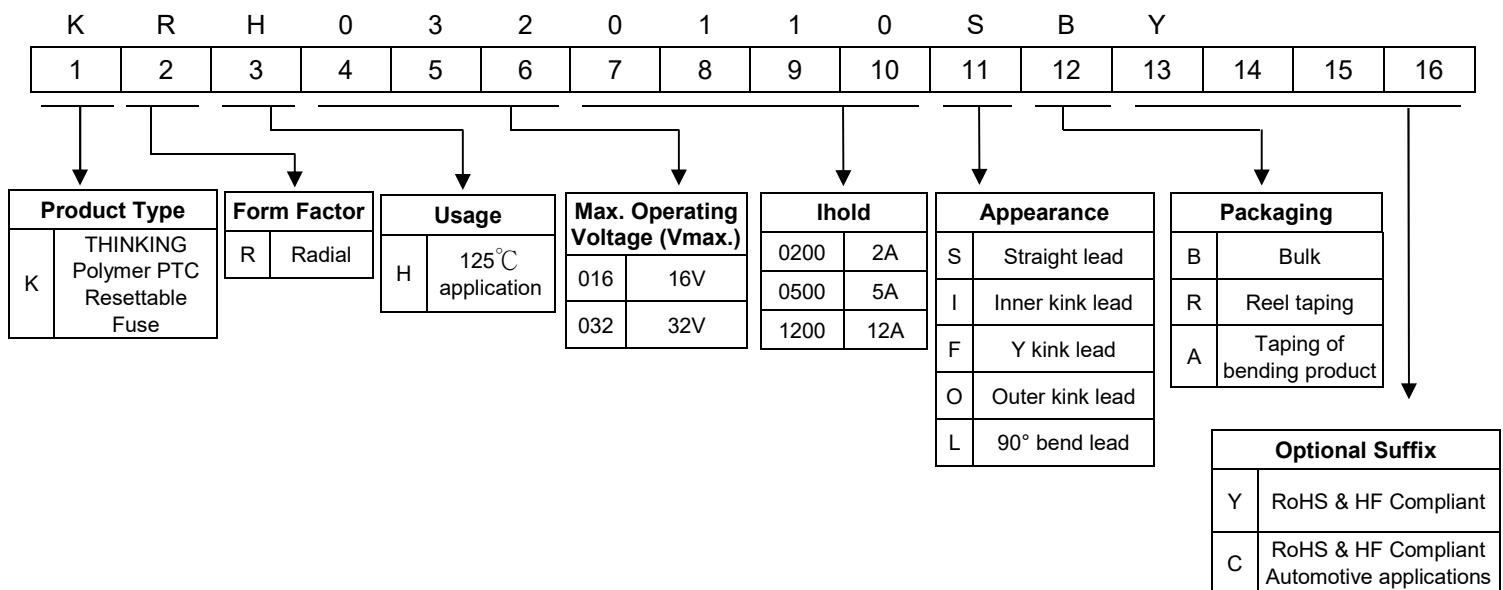

Polymer PTC Resettable Fuse: KRH Series

125°C Radial Leded Type



■ Structure and Dimensions

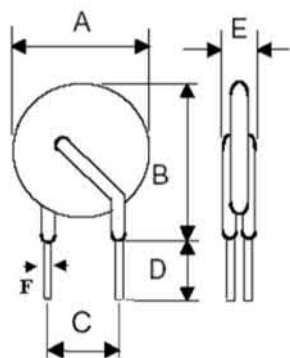

Figure 1

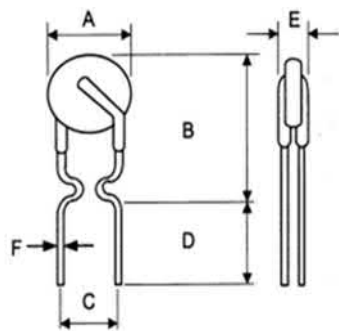

Figure 2

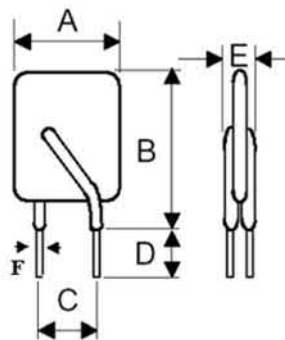

Figure 3

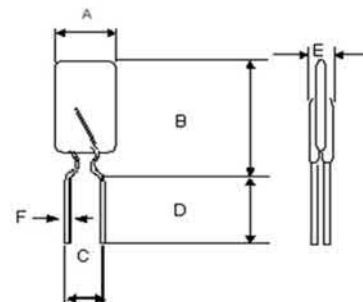

Figure 4

● KRH016

(Unit: mm)

Part No.	A	B	C		D	E	F	Figure
	Max.	Max.	Min.	Max.	Min.	Max.		
KRH0160200	9.4	14.4	4.3	5.8	7.6	3	0.5+/-0.02	1, 2
KRH0160300	8.8	13.8	4.3	5.8	7.6	3	0.8+/-0.02	3, 4
KRH0160400	10	15	4.3	5.8	7.6	3	0.8+/-0.02	3, 4
KRH0160450	10.4	15.6	4.3	5.8	7.6	3	0.8+/-0.02	3, 4
KRH0160550	11.2	18.9	4.3	5.8	7.6	3	0.8+/-0.02	3, 4
KRH0160600	11.2	21	4.3	5.8	7.6	3	0.8+/-0.02	3, 4
KRH0160650	12.7	22.2	4.3	5.8	7.6	3	0.8+/-0.02	3, 4
KRH0160700	14	21.9	4.3	5.8	7.6	3	0.8+/-0.02	3, 4
KRH0160750	14	23.5	4.3	5.8	7.6	3	0.8+/-0.02	3, 4
KRH0160800	16.5	22.5	4.3	5.8	7.6	3	0.8+/-0.02	3, 4
KRH0160900	16.5	25.7	4.3	5.8	7.6	3	0.8+/-0.02	3, 4
KRH0161000	17.5	26.5	9.4	10.9	7.6	3	0.8+/-0.02	3, 4
KRH0161100	21	26.1	9.4	10.9	7.6	3	0.8+/-0.02	3, 4
KRH0161300	23.5	28.7	9.4	10.9	7.6	3.5	1+/-0.02	3, 4
KRH0161400	23.5	28.7	9.4	10.9	7.6	3.6	1+/-0.02	3, 4
KRH0161500	23.5	28.7	9.4	10.9	7.6	3.5	1+/-0.02	3, 4

● KRH032

(Unit: mm)

Part No.	A	B	C		D	E	F	Figure
	Max.	Max.	Min.	Max.	Min.	Max.		
KRH0320050	7.4	12.7	4.3	5.8	7.6	3.3	0.5±0.02	1, 2
KRH0320070	6.9	10.8	4.3	5.8	7.6	3	0.8±0.02	3, 4
KRH0320100	9.7	13.6	4.3	5.8	7.6	3	0.8±0.02	1, 2
KRH0320300	10.2	15.5	4.3	5.8	7.6	3.8	0.8±0.02	3, 4
KRH0320500	14	24.1	4.3	5.8	11.5	3.8	0.8±0.02	3, 4
KRH0320750	21.1	24.9	9.4	10.9	7.6	3.8	0.8±0.02	3, 4
KRH0321000	23.5	27.9	9.4	10.9	7.6	4	0.8±0.02	3, 4

Polymer PTC Resettable Fuse: KRH Series

125°C Radial Leaded Type



■ Electrical Characteristics at 23°C

● KRH016

Part No.	Ihold.	Itrip	Vmax	Imax	Pd max.	Time to Trip		Resistance			Safety Approvals	
						Current (A)	Time (Sec.)	Ri min	Ri max	R1 max (Post Trip)	UL/ cUL	TUV
	Ω	Ω	Ω									
KRH0160200	2	3.8	16	100	1.4	10	4.8	0.039	0.11	0.11	V	V
KRH0160300	3	6.5	16	100	3	15	5	0.029	0.079	0.079	V	V
KRH0160400	4	7.4	16	100	3.3	20	5	0.021	0.06	0.06	V	V
KRH0160450	4.5	8.7	16	100	3.6	22.5	4	0.017	0.054	0.054	V	V
KRH0160550	5.5	10	16	100	3.5	27.5	6	0.013	0.037	0.037	V	V
KRH0160600	6	12	16	100	4.1	30	6.5	0.01	0.032	0.032	V	V
KRH0160650	6.5	13.7	16	100	4.3	32.5	7	0.009	0.026	0.026	V	V
KRH0160700	7	13.1	16	100	4	35	7	0.0087	0.025	0.025	V	V
KRH0160750	7.5	14.8	16	100	4.5	37.5	8	0.0074	0.022	0.022	V	V
KRH0160800	8	15	16	100	4.2	40	8	0.0072	0.02	0.02	V	V
KRH0160900	9	18.5	16	100	5	45	11.5	0.0061	0.017	0.017	V	V
KRH0161000	10	20.5	16	100	5.3	50	10.5	0.0051	0.015	0.015	V	V
KRH0161100	11	21.2	16	100	5.5	55	11	0.0048	0.013	0.013	V	V
KRH0161300	13	27	16	100	6.9	65	15	0.0034	0.01	0.01	V	V
KRH0161400	14	28.3	16	100	6.9	70	15.5	0.0029	0.009	0.009	V	V
KRH0161500	15	33	16	100	7	75	20	0.0027	0.0092	0.0092	V	V

Note : UL&cUL File No: E138827, TUV File No: R50615566

● KRH032

Part No.	Ihold.	Itrip	Vmax	Imax	Pd max.	Time to Trip		Resistance			Safety Approvals	
						Current (A)	Time (Sec.)	Ri min	Ri max	R1 max (Post Trip)	UL/ cUL	TUV
	Ω	Ω	Ω									
KRH0320050	0.5	1	32	100	0.9	2.5	3	0.35	1.1	1.1	V	V
KRH0320070	0.7	1.4	32	100	1.4	3.5	3.2	0.23	0.8	0.8	V	V
KRH0320100	1	1.9	32	100	1.4	5	6.2	0.15	0.43	0.43	V	V
KRH0320300	3	6	32	100	3.2	15	5	0.035	0.11	0.11	V	V
KRH0320500	5	10	32	100	5.3	25	9	0.015	0.04	0.04	V	V
KRH0320750	7.5	15	32	100	6.5	37.5	13	0.0074	0.023	0.023	V	V
KRH0321000	10	20	32	100	7.0	50	15	0.006	0.016	0.016	V	V

Note : UL&cUL File No: E138827, TUV File No: R50615566

Polymer PTC Resettable Fuse: KRH Series

125°C Radial Leaded Type



■ Marking



KRH - TKS Logo
 16 - Vmax
 0900 - Hold=9A
 **** - Date Code

■ Typical Time to Trip Curve at 23°C

KRH0160200~KRH0161500

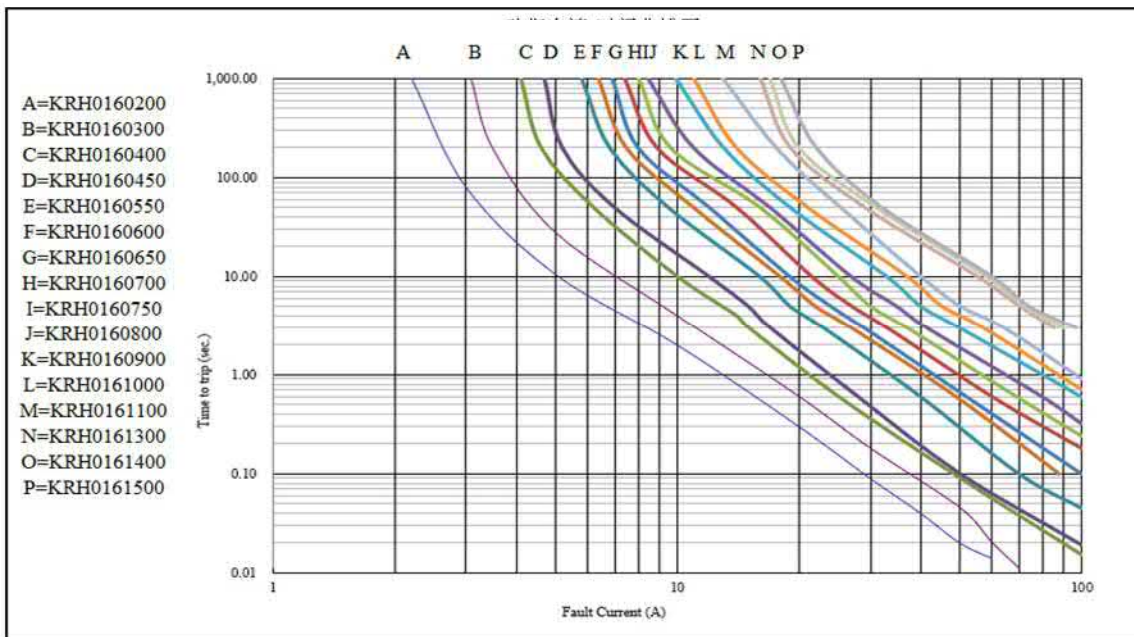

KRH0320050~KRH0321000

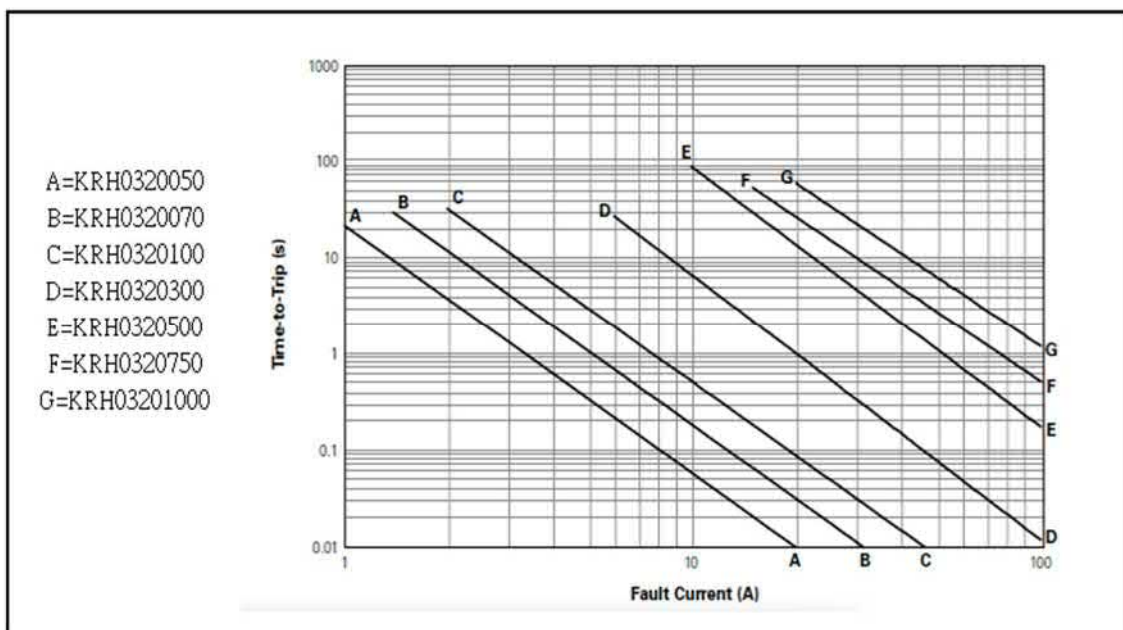

Polymer PTC Resettable Fuse: KRH Series

125°C Radial Leaded Type



■ Ihold & Itrip Thermal Derating Curve

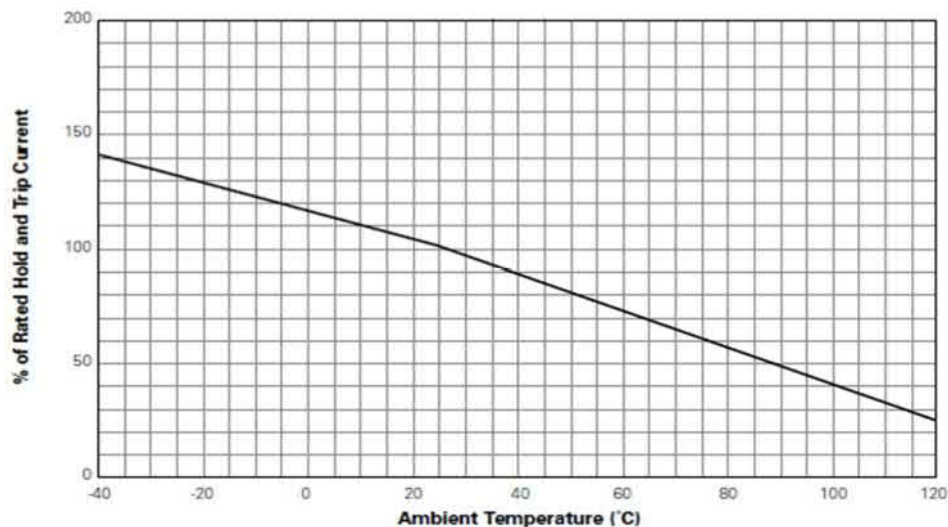

■ Ihold Thermal Derating Chart

● KRH016

(Unit: A)

Part no	Ambient Operation Temperature										
	-40°C	-20°C	0°C	20°C	23°C	40°C	50°C	60°C	70°C	85°C	125°C
KRH0160200	2.7	2.5	2.3	2.1	2	1.8	1.6	1.5	1.3	1.1	0.5
KRH0160300	4.1	3.7	3.4	3.1	3	2.7	2.4	2.2	2	1.7	0.7
KRH0160400	5.6	5.1	4.7	4.2	4	3.6	3.3	3	2.6	2.3	1
KRH0160450	6.1	5.6	5.1	4.6	4.5	4	3.6	3.3	3	2.5	1.1
KRH0160550	7.5	6.9	6.2	5.7	5.5	4.9	4.4	4	3.7	3.1	1.4
KRH0160600	8.2	7.5	6.8	6.2	6	5.3	4.9	4.4	4	3.3	1.5
KRH0160650	8.8	8.1	7.4	6.7	6.5	5.7	5.3	4.8	4.3	3.6	1.6
KRH0160700	9.5	8.7	8	7.2	7	6.2	5.6	5.2	4.7	3.9	1.7
KRH0160750	10.2	9.4	8.6	7.7	7.5	6.6	6.1	5.6	5	4.1	1.9
KRH0160800	10.9	10	9.1	8.2	8	7.1	6.4	5.9	5.3	4.4	2
KRH0160900	12.2	11.2	10.2	9.3	9	8	7.2	6.6	6	5	2.2
KRH0161000	13.6	12.5	11.4	10.3	10	8.8	8.1	7.4	6.6	5.5	2.5
KRH0161100	14.9	13.7	12.5	1.3	11	9.7	8.8	8.1	7.3	6.1	2.7
KRH0161300	17.7	16.3	14.8	13.4	13	11.4	10.5	9.6	8.6	7.2	3.3
KRH0161400	19	17.5	15.9	14.4	14	12.4	11.2	10.3	9.3	7.8	3.5
KRH0161500	20.4	18.8	17.1	15.5	15	13.2	12.1	11.1	9.9	8.3	3.8

● KRH032

(Unit: A)

Part no	Ambient Operation Temperature										
	-40°C	-20°C	0°C	20°C	23°C	40°C	50°C	60°C	70°C	85°C	125°C
KRH0320050	0.7	0.6	0.6	0.5	0.5	0.4	0.4	0.4	0.3	0.3	0.1
KRH0320070	1	0.9	0.8	0.7	0.7	0.6	0.6	0.5	0.5	0.4	0.2
KRH0320100	1.4	1.2	1.1	1	1	0.9	0.8	0.7	0.7	0.6	0.2
KRH0320300	4.1	3.8	3.42	3.1	3	2.7	2.43	2.22	1.98	1.65	0.6
KRH0320500	6.8	6.3	5.7	5.2	5	4.5	4.05	3.7	3.3	2.75	1
KRH0320750	10.2	9.4	8.55	7.7	7.5	6.7	6.075	5.55	4.95	4.125	1.5
KRH0321000	13.6	12.5	11.4	10.3	10	8.9	8.1	7.4	6.6	5.5	2

Polymer PTC Resettable Fuse: KRH Series

125°C Radial Leaded Type



■ Reliability

Item	Test Condition / Methods	Criteria
High Temperature Storage	125°C, 1000 hrs	±5% typical resistance change
Humidity Aging	85°C, 85% RH, 1000 hrs	±5% typical resistance change
Rapid Change of Temperature	125±5/-40±5°C, 10 cycles, Duration: 30 min	±5% typical resistance change
Resistance to Soldering Heat	260± 5°C, 10 ± 1 sec	No visible damage

■ Packaging (KRH016)

Devices are taped according to IEC60286-2 standards. See table below and Fig. 1~3 for details.

Dimension description	IEC Mark	Dimension (mm)	Tolerance (mm)
Sprocket hole pitch	P ₀	12.7	±0.3
Ordinate to adjacent component lead KRH0160200~ KRH0160900	P ₁	3.85	±0.7
Ordinate to adjacent component lead KRH0161000~KRH0161500		7.7	
Device pitch KRH0160200~KRH0160450	P	12.7	±1.0
Device pitch KRH0160550~KRH0161500		25.4	
Lead diameter KRH0160200	d	0.5	±0.02
Lead diameter KRH0160300~KRH0161100		0.8	
Lead diameter KRH0161300~KRH01615000		1	
Carrier tape width	W	18	-2
KRH0160200~KRH0160900	C	5	±0.8
KRH0161000~KRH0161500		10	
Top distance between tape edges	W ₂	3	Max
Hold-down tape width	W ₀	12	±1.5
Sprocket hole position	W ₁	9	-1.5
Abscissa to top KRH0160200~KRH0160450	H ₁	32.2	Max.
Abscissa to top KRH0160550~ KRH0161500		47.5	
Abscissa to plane (straight lead)	H	18	+2/-0
Abscissa to plane (kinked lead)	H ₀	16	±0.5
Sprocket hole diameter	D ₀	4	±0.2
Lead protrusion	L ₁	0.5	Max.
Tape thickness	t	0.6	±0.2
Body lateral deviation	Δh	2	Max.
Body tape plane deviation	Δp	1	Max.

Polymer PTC Resettable Fuse: KRH Series

125°C Radial Leaded Type



Figure 1. For KRH0160200

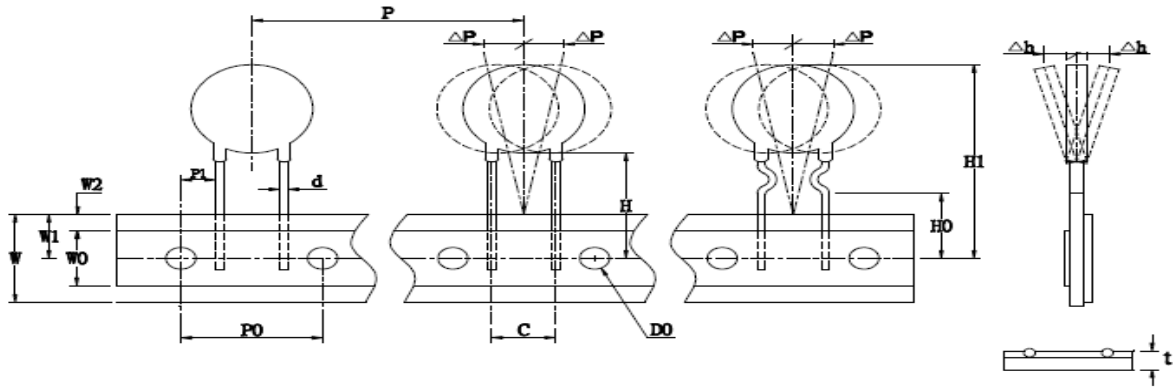

Figure 2. For KRH0160300-KRH0160900

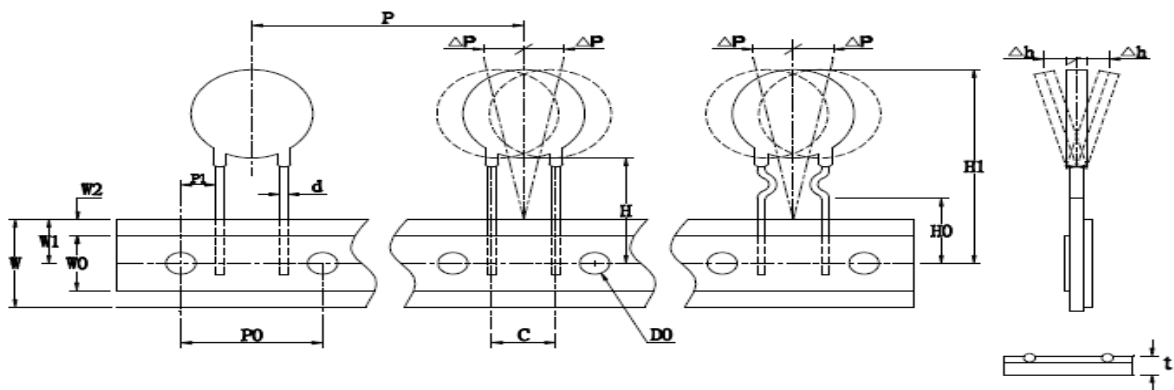
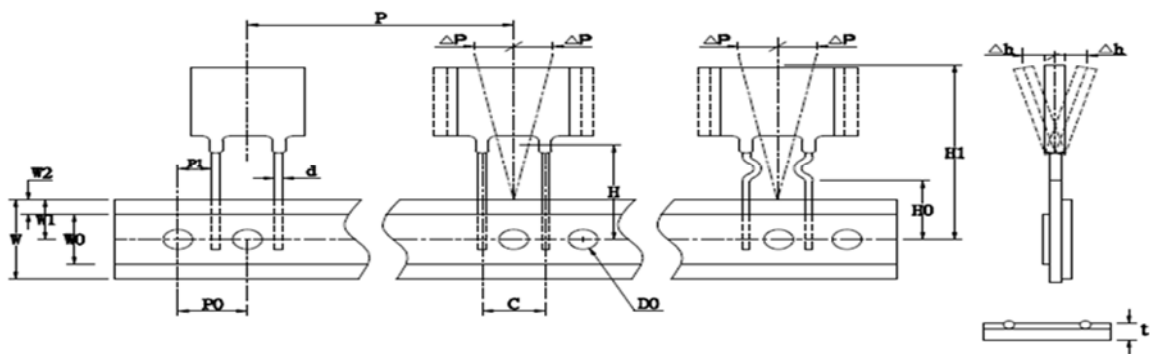

Figure 3. For KRH0161000-KRH0161500



Polymer PTC Resettable Fuse: KRH Series

125°C Radial Leaded Type



■ Packaging (KRH032)

Devices are taped according to IEC60286-2 standards. See table below and Fig. 1~3 for details.

Dimension description	IEC Mark	Dimension (mm)	Tolerance (mm)
Sprocket hole pitch	P ₀	12.70	±0.3
Ordinate to adjacent component lead KRH0320050~ KRH0320500	P ₁	3.85	±0.7
Ordinate to adjacent component lead KRH0320750~KRH03201000		7.7	
Device pitch KRH0320050~KRH0320300	P	12.7	±1.0
Device pitch KRH0320500~KRH0321000		25.4	
Lead diameter KRH0320050	d	0.5	±0.02
Lead diameter KRH0320070~KRH0321000		0.8	
Carrier tape width	W	18	-2
KRH0320050~KRH0320500	C	5	±0.8
KRH0320750~KRH0321000		10	
Top distance between tape edges	W ₂	3	Max
Hold-down tape width	W ₀	12	±1.5
Sprocket hole position	W ₁	9	-1.5
Abscissa to top KRH0320050~KRH0320300	H ₁	32.2	Max.
Abscissa to top KRH0320500~ KRG0321000		47.5	
Abscissa to plane (straight lead)	H	18	+2/-0
Abscissa to plane (kinked lead)	H ₀	16	±1.5
Sprocket hole diameter	D ₀	4	±0.2
Lead protrusion	L ₁	0.5	Max.
Tape thickness	t	0.6	±0.2
Body lateral deviation	Δh	2	Max.
Body tape plane deviation	Δp	1	Max.

Polymer PTC Resettable Fuse: KRH Series

125°C Radial Leaded Type



Figure 1. For KRH0320050, KRH0320100

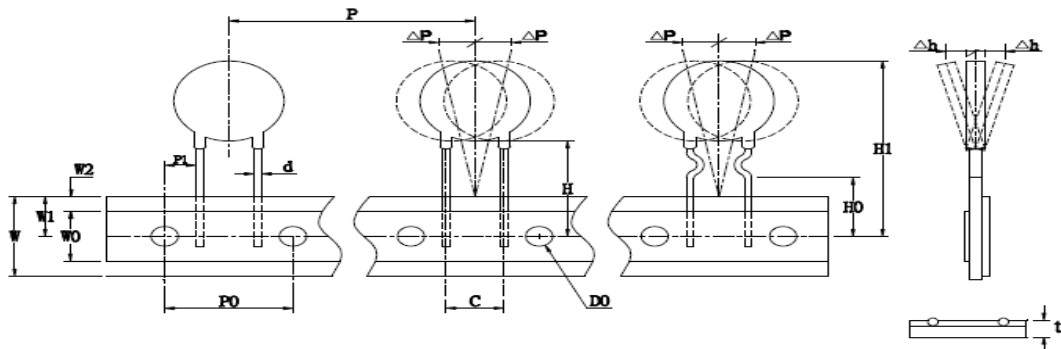

Figure 2. For KRH0320070, KRH0320300- KRH0320500

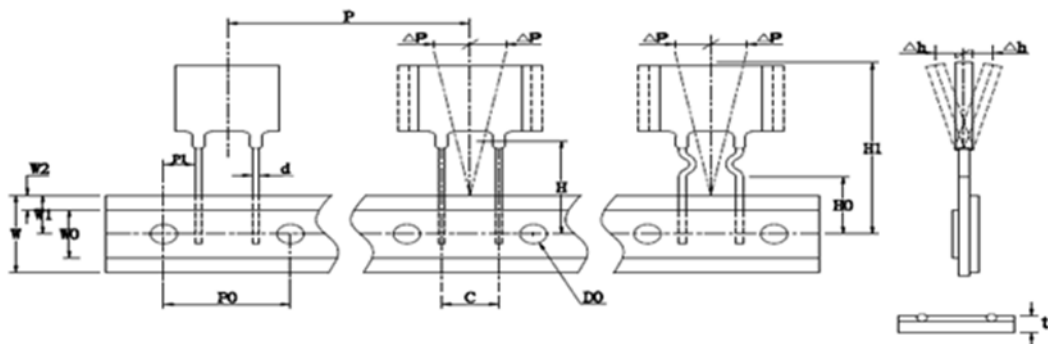
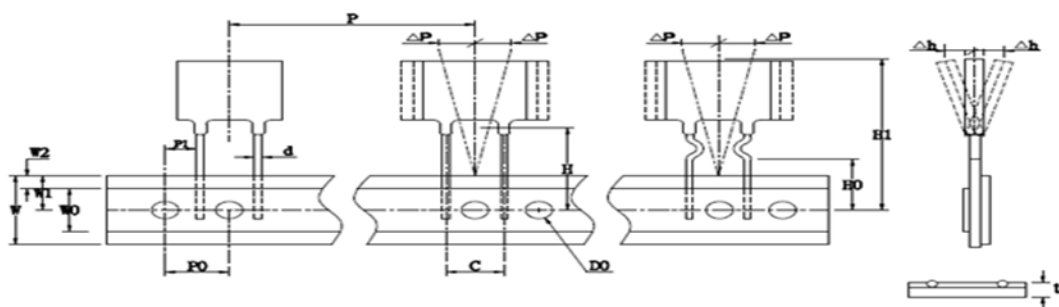

Figure 3. For KRH0320750, KRH0321000



Polymer PTC Resettable Fuse: KRH Series

125°C Radial Leaded Type



■ Reel Specification

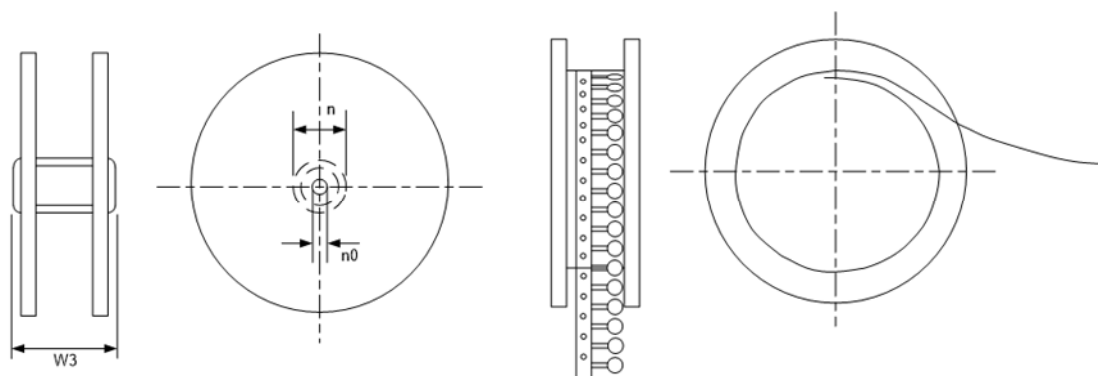

(Unit: mm)

Series	N (Min.)	n0	Reel Diameter	W3 (Max.)
KRH0160200-KRH0160800	80	31±1	340±10	46±1
KRH0320050-KRH0320500				
KRH0160900-KRH0161500				
KRH0320750-KRH0321000				55±1

■ Quantity

● Bulk Packing

Part Number	Quantity (pcs/bag)
KRH0160200~KRH0160700	500
KRH0160800~KRH0160900	
KRH0320050~KRH0320300	
KRH0161000~KRH0161100	250
KRH0161300~KRH0161500	
KRH0320500~KRH0321000	

■ Warehouse Storage Conditions of Products

● Storage Conditions:

1. Storage Temperature: -10 °C ~ + 40 °C
2. Relative humidity: ≤ 75%RH
3. Thermistors must be kept away from sunlight and stored in a non-corrosive atmosphere.

● Period of Storage: 1 year